



Powerful Tanker for Water Transportation and Spray

WATER TANKER LORRY

4000L / 5000L / 8000L / 12000L / 16000L / 18000L

OFFICE

Office. 603 6th floor 298, Beotkkot-ro, Geumcheon-gu, Seoul, Republic of Korea

Factory. 246 Gogol-gil, Deogyang-gu, Goyang-si, Gyeonggi-do, Republic of Korea

Tel. (+82)2038-0008

Email. sales@kscparts.com



Tanker Lorry

WATER TANKER LORRY

FEATURE & BENEFITS

- Water tank volume from 3,000L to 20,000L.
- Tank material can be Carbon steel, Stainless steel or Aluminum alloy.
- Super powerful water pump, efficient pump in and pump out.
- Rear working platform, Front/rear/side spray are standard equipment.
- Attractive Optional Package



DRAWING DESCRIPTION

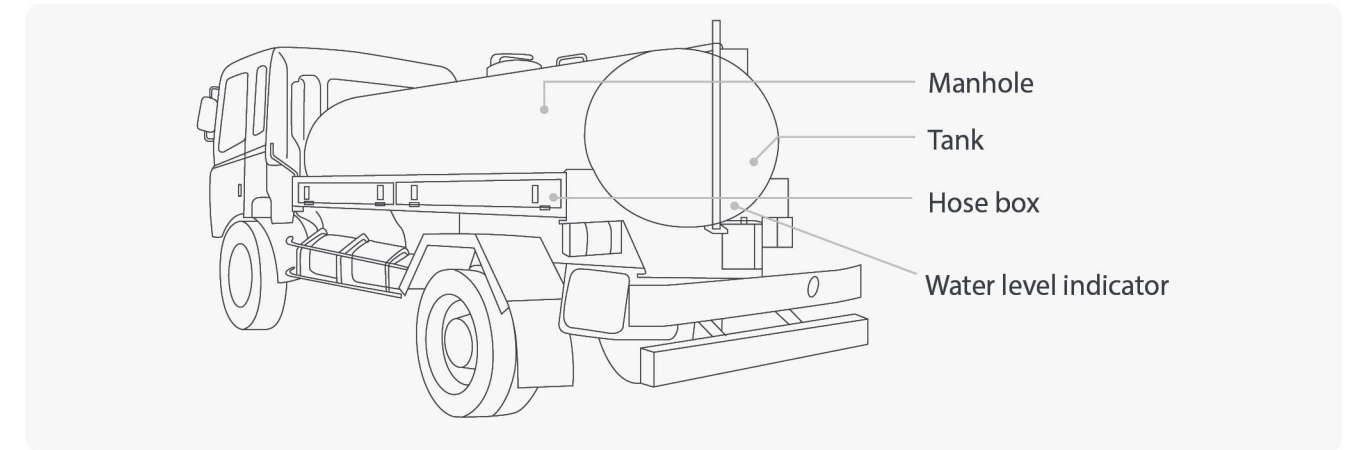

ADVANTAGES



Manholes & Walkway

The tank has a pair of manholes on the top, one toward the front and one at the rear.



Self-Priming Centrifugal Pump

This pump, the central item in the optional pump package, is powered by transmission PTO via a V belt.



Hose box

Supports efficient suction operation for all models.

WATER TANKER LORRY



▲ 4000L



▲ 5000L



▲ 8000L



▲ 12000L



▲ 16000L



▲ 18000L



Choice of Tank Sizes

Water tanks vary in volume of small and medium-sized large tanks.



Level Indicator

The level indicator, at the rear of the tank, shows the tank water level.



Suction Hose

The hose, part of the optional pump package.