

# KOREX ASPHALT PAVER

KOREX Series Asphalt Paver | Multi-function Paver



## OFFICE

**Office.** 603 6th floor 298, Beotkkot-ro, Geumcheon-gu, Seoul, Republic of Korea  
**Factory.** 246 Gogol-gil, Deogyang-gu, Goyang-si, Gyeonggi-do, Republic of Korea  
**Tel.** (+82)2038-0008  
**Email.** sales@kscparts.com

# KOREX ASPHALT PAVER PERFORMANCE ADVANTAGES

KOREX's Asphalt Paver reaches international advanced level based on technology transferred from abroad. The machine is used to pave asphalt for highway, urban road, plaza, and parking lots etc. It is the ideal machine for road construction.

# ADVANCED DESIGN&OPTIMIZED KOREX SERIES



### FLEXIBLE HOPPER

Strong carrying capacity and great feeding capacity, and meets the requirement of paving depth.



### USING A FAMOUS BRAND OF ENGINE

Provides sufficient output for a variety of challenging tasks.



### DUAL-LAYER SCREED

Unique dual-layer and stepless-extension screed changes paving width easily.



### FULL HYDRAULIC DRIVE

Hydraulics from world brand manufacturer for high reliability and prolong service life

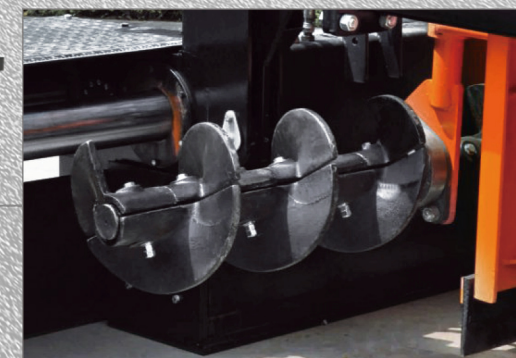

### AUGER FEEDING SYSTEM

# CORE COMPONENTS

## ASPHALT PAVER TYPE

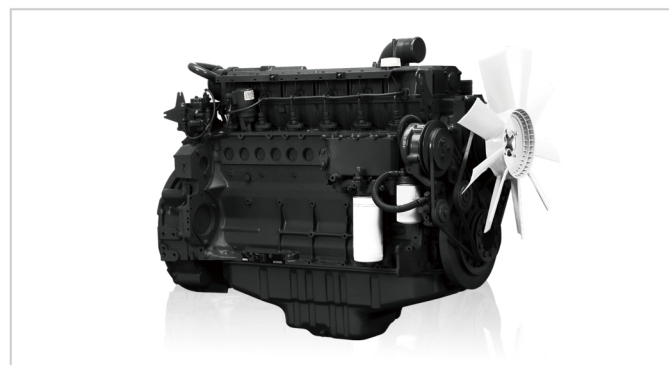

**HIGH QUALITY ENGINE**

Cummins/Volvo/shangchai/weichai engine conforming to environmental requirements offers sufficient power to suit various tough tasks.



**CENTRALIZED LUBRICATION**

Imported centralized lubrication system, automatically charging lubricating grease to all high-temperature and motion parts, to improve machine reliability.



**EASY AND CONVENIENT CONSOLE**

Could slide left hand and right hand, easy readable instrument, large colorful screen for real-time status, automatic fault diagnosis. Improves driver's drive line visibility.



**ABRASION RESISTANT HOPPER**

The hopper can be used in conjunction with hydraulic conveyors and hopper up-down floor plates to reduce material leakage from the receiving hopper while sometimes reducing manual work off-site.



**AUGER FEEDING SYSTEM**

The conveyor floor plates, screed plates, auger flight and double bushing conveyor chains all deliver long life while resisting wear from any abrasive lay down material.



**WHEEL UNDERCARRIAGE**

Quick reacting speed control ensures that responsive power is immediately available, while the wheeled undercarriage provides mobility and high speed capability when moving around the job site.

# KOREX ASPHALT PAVER

The machine is equipped with hydraulically extension screed and automatic leveling unit and can achieve good roads flatness and high density.



**EXTERIOR DRAWING**

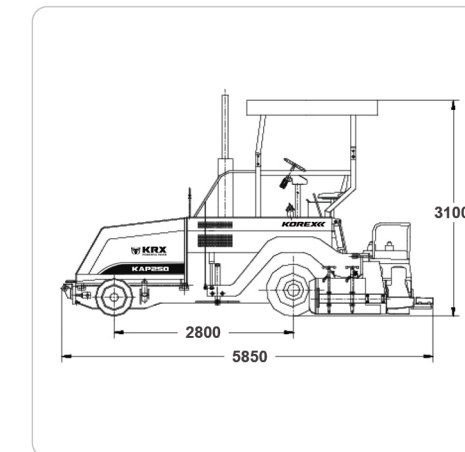

## SPECIFICATION

## ASPHALT PAVER TYPE

Model	Unit	KAP250
Paving width	mm	2,500~4,500
Max. paving thickness	mm	250
Theoretical productivity	t/h	220
Paving speed	m/min	3.01~8.97
Running speed	km/h	2.29~16.74
Machine weight	t/h	11
Engine model	-	Quan Diesel/4JR3AG7
Engine power	kw	55
Hopper capacity	t/h	10
Auto. Leveling unit	-	China made
Screed extension mode	-	Hydraulic extension
Screed vibration frequency	Hz	0~50
Screed heating mode	-	Fuel heating auto ignition
Fuel tank volume	L	143
Hydraulic tank volume	L	110
Ceiling	-	Fixed
Undercarriage	-	Wheel

\* Structure and specification are subject to change without notice.

\* In case there is any difference between the description of the machine and the substantial machine, the substantial machine should govern.

# KOREX ASPHALT PAVER

The machine is equipped with hydraulically extension screed and automatic leveling unit and can achieve good roads flatness and high density.



EXTERIOR DRAWING

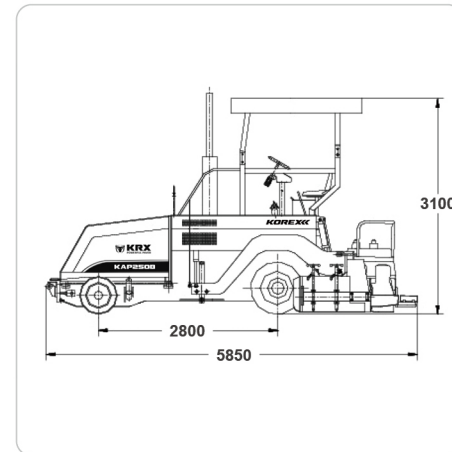

## SPECIFICATION

## ASPHALT PAVER TYPE

Model	Unit	KAP250B
Paving width	mm	2,500~4,500
Max. paving thickness	mm	250
Theoretical productivity	t/h	220
Paving speed	m/min	3.01~8.97
Running speed	km/h	2.29~16.74
Machine weight	t/h	11
Engine model	-	Cummins/QSB3.9
Engine power	kw	60
Hopper capacity	t/h	10
Auto. Leveling unit	-	China made
Screed extension mode	-	Hydraulic extension
Screed vibration frequency	Hz	0~50
Screed heating mode	-	Fuel heating auto ignition
Fuel tank volume	L	143
Hydraulic tank volume	L	110
Ceiling	-	Scaling
Undercarriage	-	Wheel

\* Structure and specification are subject to change without notice.

\* In case there is any difference between the description of the machine and the substantial machine, the substantial machine should govern.

# KOREX ASPHALT PAVER

The machine is equipped with hydraulically extension screed and automatic leveling unit and can achieve good roads flatness and high density.



EXTERIOR DRAWING

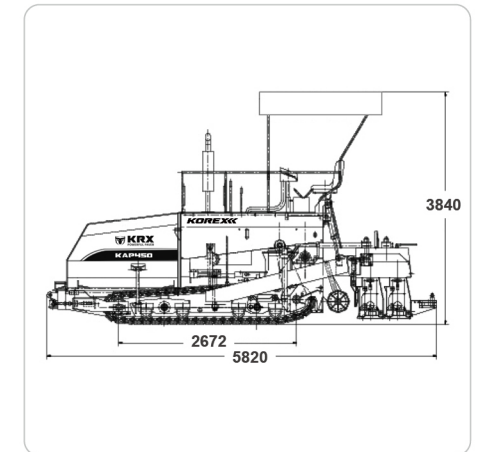

## SPECIFICATION

## ASPHALT PAVER TYPE

Model	Unit	KAP450
Paving width	mm	2,500~4,500
Max. paving thickness	mm	250
Theoretical productivity	t/h	220
Paving speed	m/min	2.03~6.07
Running speed	km/h	1.55~4.62
Machine weight	t/h	11
Engine model	-	Quan Diesel/4JR3AG7
Engine power	kw	55
Hopper capacity	t/h	10
Auto. Leveling unit	-	China made
Screed extension mode	-	Hydraulic extension
Screed vibration frequency	Hz	0~50
Screed heating mode	-	Fuel heating auto ignition
Fuel tank volume	L	110
Hydraulic tank volume	L	110
Ceiling	-	Fixed
Undercarriage	-	Crawler

\* Structure and specification are subject to change without notice.

\* In case there is any difference between the description of the machine and the substantial machine, the substantial machine should govern.

# KOREX ASPHALT PAVER

The machine is equipped with hydraulically extension screed and automatic leveling unit and can achieve good roads flatness and high density.



EXTERIOR DRAWING

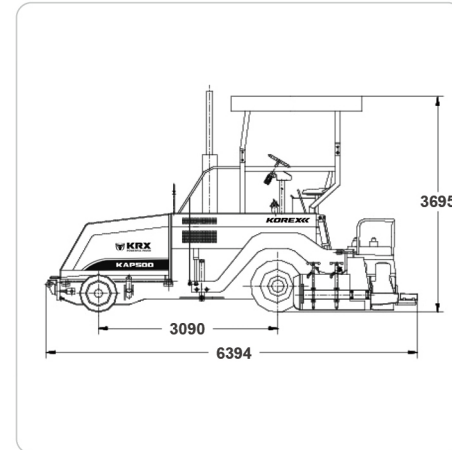

## SPECIFICATION

## ASPHALT PAVER TYPE

Model	Unit	KAP500
Paving width	mm	2,800~6,000
Max. paving thickness	mm	250
Theoretical productivity	t/h	300
Paving speed	m/min	3.07~9.16
Running speed	km/h	2.30~16.84
Machine weight	t/h	13~14.5
Engine model	-	Cummins/QSB5.9
Engine power	kw	97
Hopper capacity	t/h	12
Auto. Leveling unit	-	China made
Screed extension mode	-	Hydraulic extension
Screed vibration frequency	Hz	0~50
Screed heating mode	-	Fuel heating auto ignition
Fuel tank volume	L	200
Hydraulic tank volume	L	115
Ceiling	-	Scaling
Undercarriage	-	2-Wheel

\* Structure and specification are subject to change without notice.

\* In case there is any difference between the description of the machine and the substantial machine, the substantial machine should govern.

# KOREX ASPHALT PAVER

The machine is equipped with hydraulically extension screed and automatic leveling unit and can achieve good roads flatness and high density.



EXTERIOR DRAWING

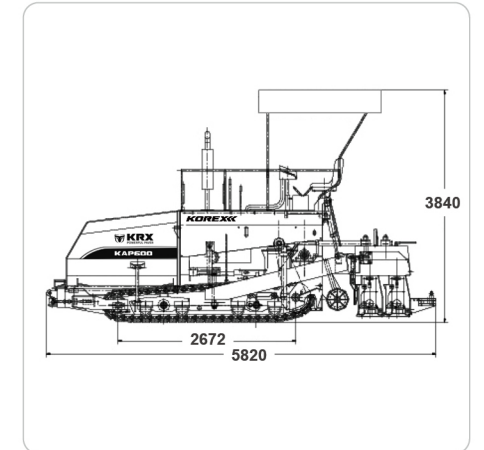

## SPECIFICATION

## ASPHALT PAVER TYPE

Model	Unit	KAP600
Paving width	mm	2,500~6,000
Max. paving thickness	mm	250
Theoretical productivity	t/h	220
Paving speed	m/min	2.03~6.07
Running speed	km/h	1.55~4.62
Machine weight	t/h	12~13
Engine model	-	Quan Diesel/4JR3AG7
Engine power	kw	55
Hopper capacity	t/h	12
Auto. Leveling unit	-	China made
Screed extension mode	-	Hydraulic extension
Screed vibration frequency	Hz	0~50
Screed heating mode	-	Fuel heating auto ignition
Fuel tank volume	L	200
Hydraulic tank volume	L	115
Ceiling	-	Scaling
Undercarriage	-	Crawler

\* Structure and specification are subject to change without notice.

\* In case there is any difference between the description of the machine and the substantial machine, the substantial machine should govern.

# KOREX ASPHALT PAVER

The machine is equipped with hydraulically extension screed and automatic leveling unit and can achieve good roads flatness and high density.



## EXTERIOR DRAWING

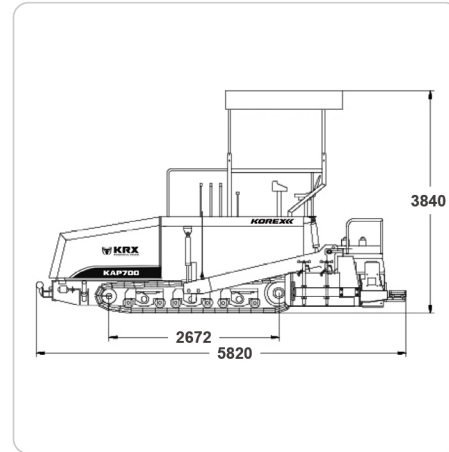

## SPECIFICATION

## ASPHALT PAVER TYPE

Model	Unit	KAP700
Paving width	mm	3,000~7,000
Max. paving thickness	mm	250
Theoretical productivity	t/h	400
Paving speed	m/min	0.96~2.86
Running speed	km/h	2.00~6.25
Machine weight	t/h	16~18
Engine model	-	Cummins/QSB5.9
Engine power	kw	97
Hopper capacity	t/h	12
Auto. Leveling unit	-	China made
Screed extension mode	-	Hydraulic extension
Screed vibration frequency	Hz	0~50
Screed heating mode	-	Fuel heating auto ignition
Fuel tank volume	L	190
Hydraulic tank volume	L	210
Ceiling	-	Scaling
Undercarriage	-	Crawler

\* Structure and specification are subject to change without notice.

\* In case there is any difference between the description of the machine and the substantial machine, the substantial machine should govern.

# CORE COMPONENTS

## MULTI-FUNCTION PAVER TYPE



## FEATURE & DESCRIPTION



**HIGH QUALITY ENGINE**

Standard engine is Shanghai Diesel from world class manufacturer, 6-cylinder and water cooled, ample reserve power for all operating conditions.



**CENTRALIZED LUBRICATION**

Imported centralized lubrication system, automatically charging lubricating grease to all high-temperature and motion parts, to improve machine reliability.

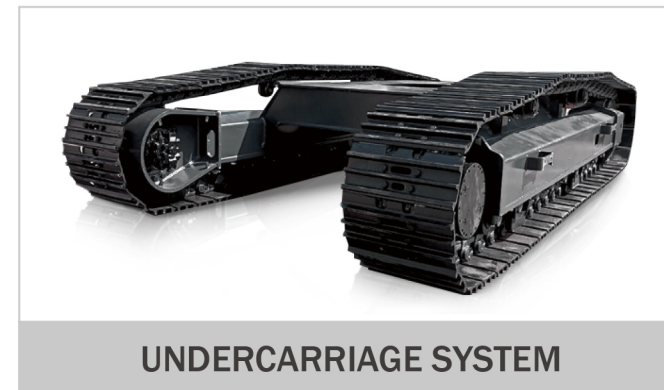

**UNDERCARRIAGE SYSTEM**

Pump, motor and speed reducer actualize full-hydraulic independent drive at single side, imported quality parts for complicated construction condition.



**DOUBLE TAMPERS WITH SCREED VIBRATIONS**

The paver material handling system design incorporates special hardness and extra thick, wear resistant components.

# KOREX MULTI-FUNCTION PAVER

The machine is equipped with hydraulically extension screed and automatic leveling unit and can achieve good roads flatness and high density.



EXTERIOR DRAWING

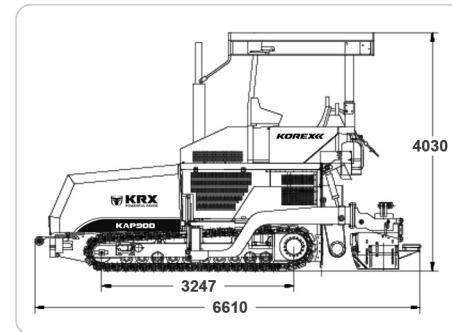

## SPECIFICATION

### MULTI-FUNCTION PAVER TYPE

Model	Unit	KAP900	KAP950	KAP1250
Paving width	mm	3,000~9,000	3,000~9,500	3000~12,500(Stabilized soil 9,500)
Max. paving thickness	mm	32	320	320
Theoretical productivity	t/h	700	700	800
Paving speed	m/min	0~16	0~16	0~14
Running speed	km/h	0~2.39	0~2.39	0~2.55
Drive system	-	Full hydraulic	Full hydraulic	Full hydraulic
Machine weight	t/h	21~27	21~27.5	21~30.5
Engine model	-	Shanghai Diesel/SC8D190G2B1		
Engine power	kw	140	140	140
Track shoe width	mm	320	320	320
Hopper capacity	t/h	16	16	16
Auto. Leveling unit	-	China made(part imported)		
Auger diameter	mm	400	400	420, 360
Tamper impact stroke	mm	Primary 5/Subsidiary 0, 3, 6, 9, 12		
Tamper impact times	nos/min	0~1,500	0~1,500	0~1,500
Screed extension mode	-	Mechanical joint	Mechanical joint	Mechanical joint
Screed vibration frequency	Hz	0~50	0~50	0~50
Screed heating mode	-	Gas heating	Gas heating	Gas heating
Display	-	Germany/DI3 Color graphic display		
Controller	-	RC Series/Germany	RC Series/Germany	RC Series/Germany
Centralized lubrication	-	Imported	Imported	Imported
Material level unit	-	TYP Series/China made	TYP Series/China made	TYP Series/China made
Undercarriage	-	Crawler	Crawler	Crawler

# KOREX MULTI-FUNCTION PAVER

The machine is equipped with hydraulically extension screed and automatic leveling unit and can achieve good roads flatness and high density.



EXTERIOR DRAWING

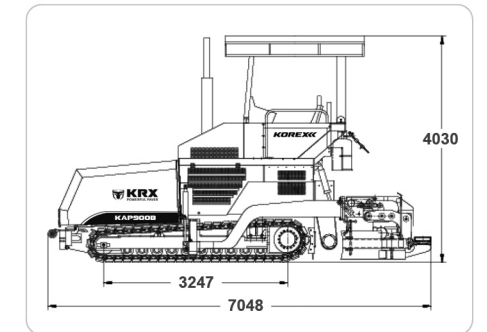

## SPECIFICATION

### MULTI-FUNCTION PAVER TYPE

Model	Unit	KAP900B
Paving width	mm	3,000~9,000
Max. paving thickness	mm	360
Theoretical productivity	t/h	800
Paving speed	m/min	0~16
Running speed	km/h	0~2.4
Drive system	-	Full hydraulic
Machine weight	t/h	21~27
Engine model	-	Shanghai Diesel/SC9D240G2
Engine power	kw	177
Track shoe width	mm	320
Hopper capacity	t/h	16
Auto. Leveling unit	-	China made(part imported)
Auger diameter	mm	420, 360
Tamper impact stroke	mm	Primary 5/Subsidiary 0, 3, 6, 9, 12
Tamper impact times	nos/min	0~1,500
Screed extension mode	-	Mechanical joint
Screed vibration frequency	Hz	0~50
Screed heating mode	-	Gas heating
Display	-	American/DP570
Controller	-	American/MC024
Centralized lubrication	-	Imported
Material level unit	-	TYP Series/China made
Undercarriage	-	Crawler

# KOREX MULTI-FUNCTION PAVER

The machine is equipped with hydraulically extension screed and automatic leveling unit and can achieve good roads flatness and high density.



EXTERIOR DRAWING

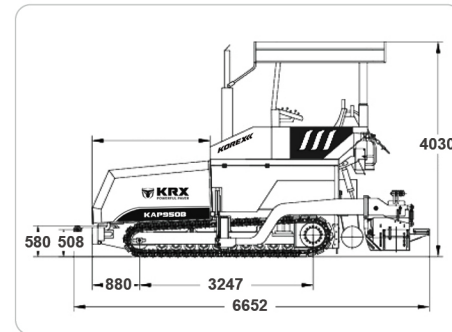

## SPECIFICATION

## MULTI-FUNCTION PAVER TYPE

Model	Unit	KAP950B
Paving width	mm	3,000~9,500
Max. paving thickness	mm	360
Theoretical productivity	t/h	800
Paving speed	m/min	0~16
Running speed	km/h	0~2.4
Drive system	-	Full hydraulic
Machine weight	t/h	21~27.5
Engine model	-	Shanghai Diesel/SC9D240G2
Engine power	kw	177
Track shoe width	mm	320
Hopper capacity	t/h	16
Auto. Leveling unit	-	China made(part imported)
Auger diameter	mm	420, 360
Tamper impact stroke	mm	Primary 5/Subsidiary 0, 3, 6, 9, 12
Tamper impact times	nos/min	0~1,500
Screed extension mode	-	Mechanical joint
Screed vibration frequency	Hz	0~50
Screed heating mode	-	Gas heating
Display	-	American/DP570
Controller	-	American/MC024
Centralized lubrication	-	Imported
Material level unit	-	TYP Series/China made
Undercarriage	-	Crawler

# KOREX MULTI-FUNCTION PAVER

The machine is equipped with hydraulically extension screed and automatic leveling unit and can achieve good roads flatness and high density.



EXTERIOR DRAWING

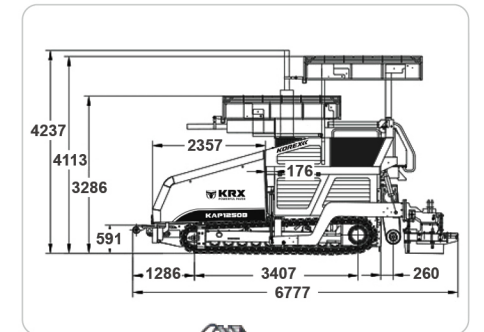

## SPECIFICATION

## MULTI-FUNCTION PAVER TYPE

Model	Unit	KAP1250B
Paving width	mm	3,000~12,500
Max. paving thickness	mm	400
Theoretical productivity	t/h	1,000
Paving speed	m/min	0~16
Running speed	km/h	0~2.8
Drive system	-	Full hydraulic
Machine weight	t/h	21~30.5
Engine model	-	VOLVO/TAD721VE
Engine power	kw	195
Track shoe width	mm	320
Hopper capacity	t/h	16
Auto. Leveling unit	-	China made(part imported)
Auger diameter	mm	480, 400
Tamper impact stroke	mm	Primary 5/Subsidiary 0, 3, 6, 9, 12
Tamper impact times	nos/min	0~1,500
Screed extension mode	-	Mechanical joint
Screed vibration frequency	Hz	0~50
Screed heating mode	-	Gas heating
Display	-	American/DP570
Controller	-	American/MC024
Centralized lubrication	-	Imported
Material level unit	-	TYP Series/China made
Undercarriage	-	Crawler